

# Vinylcomfort FLOORING COLLECTION

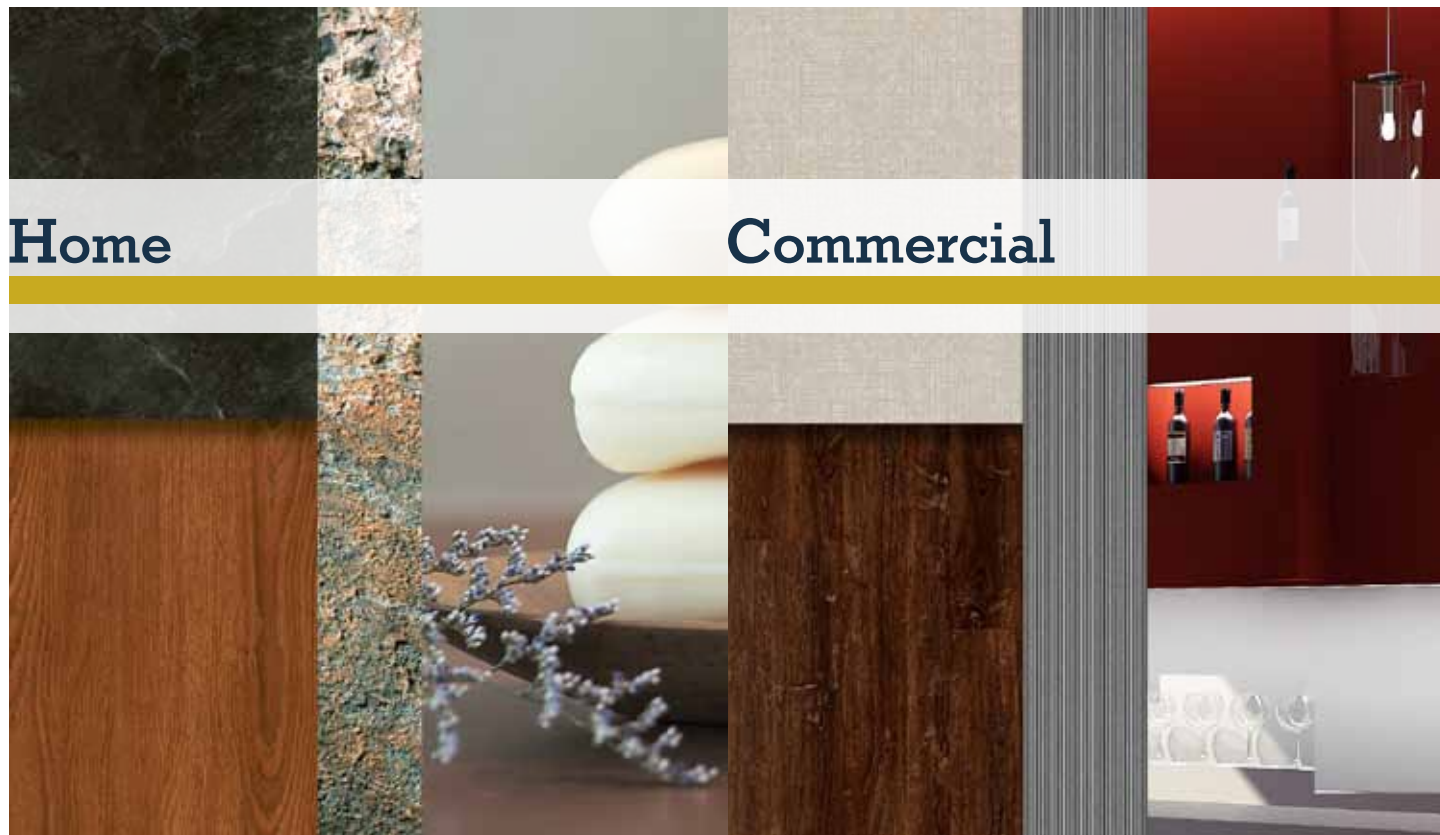

Home

Commercial

Nature at your feet

  
**WICANDERS®**



# Excellence in flooring



Amorim Revestimentos, a company of the Portuguese Amorim Group, with over 130 years of experience in selected cork products, has developed unique flooring and wall covering solutions throughout its history. Amorim Revestimentos sells its products in more than 51 countries and is known throughout the world as a pioneer in creating top-quality, ground-breaking solutions.

Reflecting a highly sustainable development, the Amorim Group developed a revolutionary process that is adapted to nature's rhythms. The first extraction of cork from the cork oak tree occurs only twenty-five years after planting, following which it is harvested in nine-year cycles, without ever damaging the tree in any way. This method allows the cork oak forest – montado - to fulfil its role of fixing CO<sub>2</sub>, thus actively contributing to reduce global warming.

The regular extraction of cork is also a decisive contributor to sustainability: environmental (conserving biodiversity and preventing desertification), social (population settlement and jobs creation) and economic. The company's in-depth knowledge and respect for nature, its continuous investment in technological innovation and highly-specialised staff, have guaranteed its leading position in the international field. **Wicanders** has strengthened its existing cork products (**Corkcomfort**) and wood-on-cork products (**Woodcomfort**), by investing in new product lines such as vinyl (**Vinylcomfort**), linoleum (**Linocomfort**), and parquet (**Parquet**), towards a new phase marked by the evolution from a cork manufacturer to a flooring solutions company.

Cutting-edge technology, know-how, creativity and audacity are merged into an avant-garde approach inspired on nature's values.



Cherry  
Palisander

Amber Cherry

3



## Setting **new standards** for flooring

As a result of advanced technological research, this new flooring for public and private areas has changed the way we envision spaces, suggesting a more liberating and inspiring experience.

Following the latest trends in flooring, **Vinylcomfort** is a new concept in Luxury Vinyl Tile (LVT) floating floors, surpassing existing glue-down floor solutions and other similar surfaces. Positioned as a forerunner in the vanguard of vinyl flooring for residential and commercial environments, **Vinylcomfort** combines a strong design element with the benefits of an innovative structure supported by a double cork layer. The new **Vinylcomfort** collection has revolutionized the range of avant-garde flooring solutions by perfectly interpreting the textures and patterns of noble hardwoods, exotic stones and innovative materials, offering numerous choices in the creation of comfortable and distinctive atmospheres, achieving a perfect match between sustainability and breakthrough solutions.



# A new era for vinyl flooring

With solid technological know-how in developing cork-based flooring, **Wicanders** has innovated in the vinyl flooring market, presenting a pioneering product for home and commercial spaces.

Thanks to its unique characteristics, **Vinylcomfort** distinguishes from traditional glue-down LVT floors by presenting itself in a floating solution, being also superior to other existing vinyl floating solutions, due to a more advanced structure that incorporates an additional cork layer.

The natural characteristics of cork provide greater walking comfort, as well as improved acoustic properties. The double cork layer also plays a fundamental role in providing heat insulation, offering you unrivalled comfort with reduced energy costs, improving eco-efficiency.

**Vinylcomfort's** excellence is enhanced by the nobility of its visuals. Advanced techniques allowed the beauty and texture of various materials to be re-invented, resulting in a stylish collection. Furthermore, innovative features and dimensions, not available in similar competitor products, enriched even more this collection.

The advantages of this product are not limited to aesthetics, also inviting you to enjoy your time. Providing you with a fast and easy installation, it doesn't require a complex subfloor preparation or the use of adhesives that represent increased costs, time consumption and environmental harm.

From production to installation, **Vinylcomfort** stands out for its exceptional design and excellent performance.

Developed for homes, hotels, shops, offices and other locations where fashion, durability and cleanliness of the floor are decisive factors, this line exceeds all the expectations of interior designers, architects and builders. Surprising ambiances can be created at reasonable cost and within a short period of time. After installation, **Vinylcomfort** confirms its efficiency, ensuring many years of easy maintenance and proven resistance to wear and tear.



Cinder Oak

Auburn Oak



**Explore** our essence



# Your design for life

## **FEEL NATURAL**

### **Natural and realistic effects**

The matte surface, combined with a wide range of patterns, allows a true material interpretation with effects capable of inspiring unique sensations. The excellence of the visuals is reinforced by a wide range of dimensions available.

## **FEEL UNIQUE**

### **Endless options**

Architects and interior designers now have at their disposal a unique collection inspired by nature. Following the latest trends on diverse surfaces as wood, concrete, ceramics, aged metal or natural stone, **Vinylcomfort** exhibits genuine textures felt through a simple look. Create sophisticated or rustic ambiances in new or renovated spaces.

## **FEEL SAFE**

### **A long-lasting surface**

Extremely resistant to intense everyday wear and tear, **Vinylcomfort** is your floor for life, at home, shop or office.



# Your wellbeing

## **FEEL RELAXED**

### **Quiet environments**

It is a well known fact that noise contributes to stress. Composed by a double cork layer, **Vinylcomfort** offers remarkable sound reduction, promoting a harmonious and relaxing environment.

## **FEEL WARM**

### **Welcoming environments**

The natural properties of cork play a fundamental role in providing heat insulation, offering you unrivalled comfort and hospitality with reduced energy costs. A benefit not only to your investment, but to your health as well.

## **FEEL COMFORTABLE**

### **Comfort that walks alongside you**

**Vinylcomfort** was designed to provide comfort in the most demanding environments. The double cork layer is soft enough to reduce the impact on your joints and back, allowing you to enjoy natural comfort in the simple act of walking.



# Your time

## FEEL POWERFUL

### We create, you live

**Vinylcomfort** saves you time and money. Quick and easy to install, with the CORKLOC® system you are able to transform your environment without interfering with your day-to-day activities, and also profit from its re-use, if you wish to.

Commercial spaces can benefit from a complete overnight transformation with no need to close. It does not require adhesives or complex subfloor preparation. Furthermore, this product comes with an all around edge sealing for increased moisture protection.

## FEEL FREE

### Extra time in your day

Thanks to its easy maintenance, **Vinylcomfort** does not require any special care, providing you with the time and freedom to do what you really like. However, Wicanders offers you a complete care and maintenance system if needed. With a sophisticated look, high performance and durability, this is the floor that invites you to enjoy life.



Raw Umber

Volcanic Ash

## A revolutionary concept

**Wicanders** presents a cutting-edge product developed to meet your present expectations and future needs!

**Wicanders** is the first and only brand to offer a floating vinyl product with a double cork layer, allowing unique performance in what concerns thermal insulation, walking comfort and acoustical behavior (impact sound reduction and step sound).

## Atmospheres full of character

Fell your essence in the room you create. See your personality brought to life through 14 unique references with advanced embossing features so that no detail goes unnoticed.

**Vinylcomfort** will enrich your space with charm and charisma.

## Versatility

A floating product combining cork and vinyl, available in two formats conceived for a perfect recreation of the original materials:

905 x 295 x 10.5 mm – non-wood visuals

1220 x 185 x 10.5 mm – wood visuals



Home

Commercial

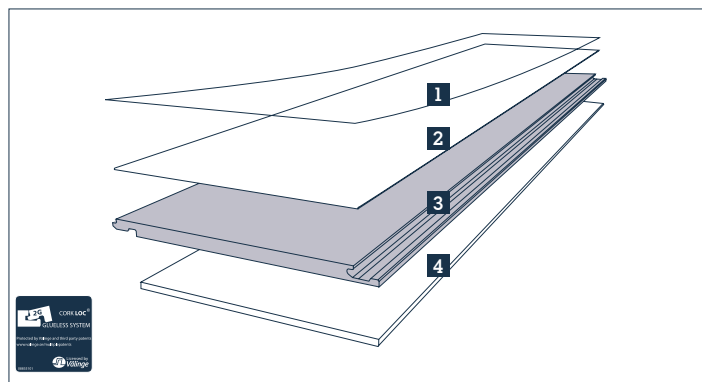

- 1.0 Vinyl sheet (with 0,3mm wear layer)
  - 2.0 High density cork core layer
  - 3.0 HDF – High Density Fibreboard with CORKLOC®
  - 4.0 Integrated insulating cork underlay
- All around edge sealing

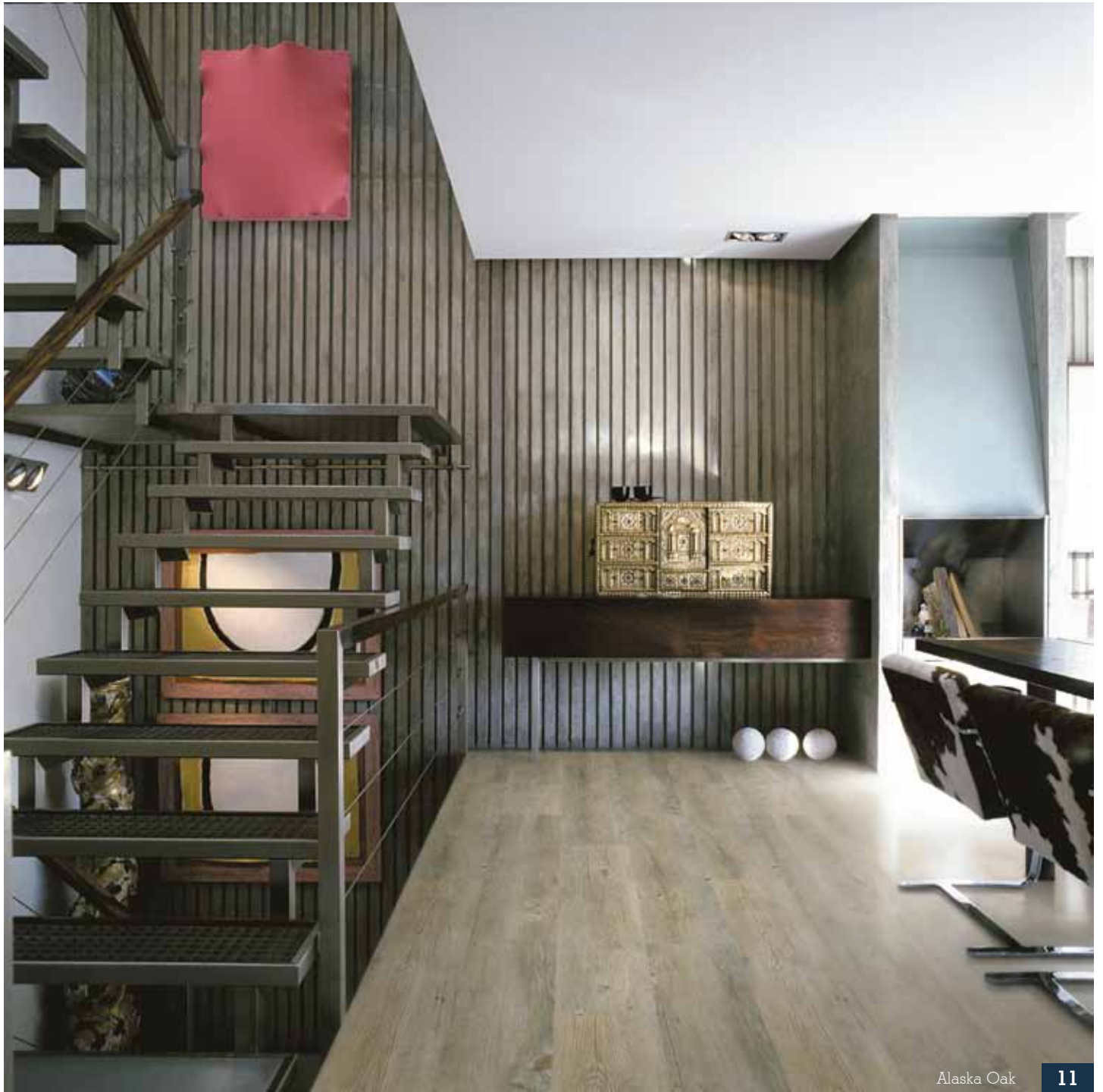

# Vinylcomfort visuals

---



Alaska Oak



Chalk Oak



European Oak



Provence Oak



Canyon Oak



Smoked Oak



Amber Cherry



Cherry



American Walnut



Palisander



Bianco Travertine



Volcanic Ash



Raw Umber



Coal Slate

### Extra performance for the most demanding environments

To address the needs of demanding commercial spaces, **Wicanders** has developed a Commercial collection. With a 0,5mm wear layer, this product is suitable for heavy traffic areas until Class 33 (acc. EN685).

### Unique designs for distinctive ambiances

Create inimitable design options for residential or commercial areas. **Wicanders** has created 14 exclusive visuals from noble wood species to exciting abstract designs.

The character of these visuals is emphasized by the 4 sides micro beveled and refined embossing features.

### Innovation

To respect the uniqueness of the visuals, new formats were selected:

605x445x10.5mm – non-wood visuals

1220x185x10.5mm – wood visuals

The resistance of the wear layer combined with a ceramic finish, allows us to give 25 years warranty for residential areas and 15 years for commercial areas until class 33.



Home



Commercial

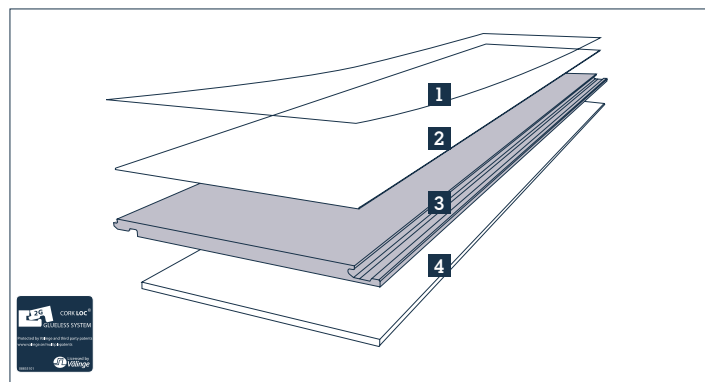

- 1.0 Vinyl sheet (with 0,5mm wear layer)
  - 2.0 High density cork core layer
  - 3.0 HDF – High Density Fibreboard with CORKLOC®
  - 4.0 Integrated insulating cork underlay
- All around edge sealing



# Vinylcomfort visuals



Steel Petal



Mystic Tweed



Pearl Petal



Midnight Tweed



Ebony Petal



Linen Cherry

**COMMERCIAL**  
FLOORING  
COLLECTION



Sand Oak



European Cherry



Wheat Pine



Elegant Oak



Auburn Oak



Tobacco Pine



Cinder Oak



Exotic Cherry

This sample image is cut from a larger piece. Decor and shade may vary slightly.

# Product selector

## HOME FLOORING COLLECTION

Finishing		PU acrylate UV	PU acrylate UV
Thickness	mm	10,5	10,5
	inches	13/32	13/32
Dimension	mm	905x295	1220x185
	Inches	35-5/8x11-5/8	48-1/32x7-9/32
Embossing		Yes	Yes
Bevelling		No	No
<b>Reference</b>			
Raw umber		B0C0001	
Coal Slate		B0C1001	
Bianco Travertine		B0C2001	
Volcanic Ash		B0C3001	
Alaska Oak			B0Q0003
Chalk Oak			B0Q1003
European Oak			B0Q2004
Provence Oak			B0Q3003
Canyon Oak			B0Q4003
Smoked Oak			B0Q5003
Cherry			B0Q6003
Amber Cherry			B0Q7003
Palisander			B0Q8003
American Walnut			B0Q9004



## COMMERCIAL FLOORING COLLECTION

Finishing		Ceramic Finish	Ceramic Finish
Thickness	mm	10,5	10,5
	inches	13/32	13/32
Dimension	mm	605x445	1220x185
	Inches	23-13/16x17-4/8	48-1/32x7-9/32
Embossing		Yes	Yes
Bevelling		4 sides	4 sides
<b>Reference</b>			
Steel Petal		B0C4001	
Mystic Tweed		B0C5001	
Pearl Petal		B0C6001	
Midnight Tweed		B0C7001	
Ebony Petal		B0C8001	
Linen Cherry			B0R0001
Sand Oak			B0R1001
European Cherry			B0R2001
Wheat Pine			B0R3001
Elegant Oak			B0R4001
Auburn Oak			B0R5001
Tobacco Pine			B0R6001
Cinder Oak			B0R7001
Exotic Cherry			B0R8001

# Technical Data Sheet

Vinylcomfort PU acrylate UV  
1220x185x10,5; 905x295x10,5 (mm)

Vinylcomfort Ceramic  
1220x185x10,5; 605x445x10,5 (mm)

Level of use Domestic	EN 685	Class	23		23	
Level of use Commercial	EN 685	Class	32		33	
<b>General properties EN 14085 + EN 649</b>	<b>Standard- Test Method</b>	<b>Unit</b>	<b>Specification</b>	<b>Specification</b>		
Dimensions With Length	EN 427	%	"± 0,10 up to max. 0,5 mm max. 2,0 mm"	"± 0,10 até max. 0,5 mm max. 2,0 mm"		
Overall thickness	EN428	mm	± 0,25	± 0,25		
Squareness	EN427	mm	< 0,50	< 0,50		
Straightness measured at the surface layer	EN427	mm	< 0,30	< 0,30		
Apparent density	EN 672	Kg/m <sup>3</sup>	Nominal value (900) ± 50	Nominal value (960) ± 50		
Mass per unit area	EN 430	g/m <sup>2</sup>	Nominal value (9600) - 10 % + 13%	Nominal value (10150) - 10 % + 13%		
Dimensional stability (humidity)	EN 669 (Annex C)	mm	< 5	< 5		
Openings between panels	EN 14085 (Annex B)	mm	< 0,20	< 0,20		
Height difference between panels	EN 14085 (Annex B)	mm	< 0,20	< 0,20		
Flatness of the panel (Length - Concave / Convex)	EN 14085 (Annex A)	%	< 0,50 / < 1,0	< 0,50 / < 1,0		
Flatness of the panel (Width - Concave / Convex)	EN 14085 (Annex A)	%	< 0,10 / < 0,15	< 0,10 / < 0,15		
Residual indentation	EN 433	mm	< 0,15	< 0,15		
Colour fastness	EN ISO 105-BO2	Escala de azuis	> 6	> 6		
<b>Classification properties - EN 649 + EN 14085</b>						
Wearing Group	EN 660-1	Thickness loss (Δ l mm)	Wear group T	Wear group T		
Overall thickness - Vinyl + cork layer (wearing Group T)	EN 428	mm	3,2	3,2		
Wear layer thickness (wearing Group T)	EN 429	mm	0,3	0,5		
Chair leg resistance	EN 424	Visual effect	No damage shall be visible after testing with a type 2 foot	No damage shall be visible after testing with a type 2 foot		
Castor chair test	EN425	Visual effect - after 25 000 cycles	"No disturbance to the surface other than slight change in appearance and no delamination shall occur"	"No disturbance to the surface other than slight change in appearance and no delamination shall occur"		
<b>Safety properties - EN14041</b>						
Fire resistance	EN13501-1	Class	Bfl s1	Bfl s1		
Slip Resistance	EN 13893	Class	DS	DS		
Formaldehyde emission	DIN EN 717-1/2	Class	E1	E1		
Electrical behaviour	EN 1815	kV	Anti-static	Anti-static		
Content pentachlorophenol (PCP)	"CEN/TR 14823 (Ihd-W 409)"	mg/Kg	PCP free	PCP free		
<b>Additional properties</b>						
Stains Resistance	EN 423 (a)	Grade	Grade 0 (b)	Grade 0 (b)		
Thermal resistance	EN 12664	m <sup>2</sup> K/W	R <0,15	R <0,15		
Impact sound reduction	ISO 140-8	dB (Δ Lw)	16	16		
Step sound	NF S 31 - 074	dB (L n,e,w)	81	81		

(a) The following products were tested: Desinfectant, C2H5OH, NH4OH, Citric Acid, Iodine

(b) - Grade 0 - Unchanged / Grade 1 - Very little change / Grade 2 - Little change / Grade 3 - Change / Grade 4 - Strong Change

(b) Note - The results for all the products were "unchanged", with exception of Iodine - "Little change"



AMORIM

Excellence in flooring



**NL/BE/LU/FR/GB** Amorim Benelux B.V., +31 166 604 111 ..... info.ar.nl@amorim.com

**DE** Amorim Deutschland GmbH, +49 4221 59 301 ..... germany.ar.de@amorim.com

**AT** Amorim Flooring Austria, +43 1 545 16 51 0 ..... austria.ar.de@amorim.com

**CH** Amorim Flooring (Switzerland) AG, +41 41 726 20 20 . info@amorim.ch

**PT** Amorim Revestimentos S.A., +351 22 747 5250 ..... aid.ar@amorim.com

**ES** Amorim Revestimentos, S.A., +34 902 307 407 ..... info.ar.es@amorim.com

**CN** Amorim Revestimentos - Beijing, +86 10 58672159 ..... amorimre@macau.ctm.net

**JP** Amorim Japan Corporation, +81 50 1184 5995 ..... otoiawase-ar@amorim.co.jp

**DK/FI/NO/SE** Amorim Flooring Nordic A/S, +45 44 681 900 ..... mail@amorim-flooring.dk

**PL** Dom Korkowy, Sp. z o.o., +48 12 637 9639 ..... krakow@domkorkowy.pl

**US/CA** Amorim Flooring North America, +1 410 553 6062 ..... info.ar.us@amorim.com

**Others** Amorim Revestimentos, S.A., +351 22 747 5600 ..... geral.ar@amorim.com

[www.wicanders.com](http://www.wicanders.com)

